

# PND Panel Fan

## Direct Drive, Design 1

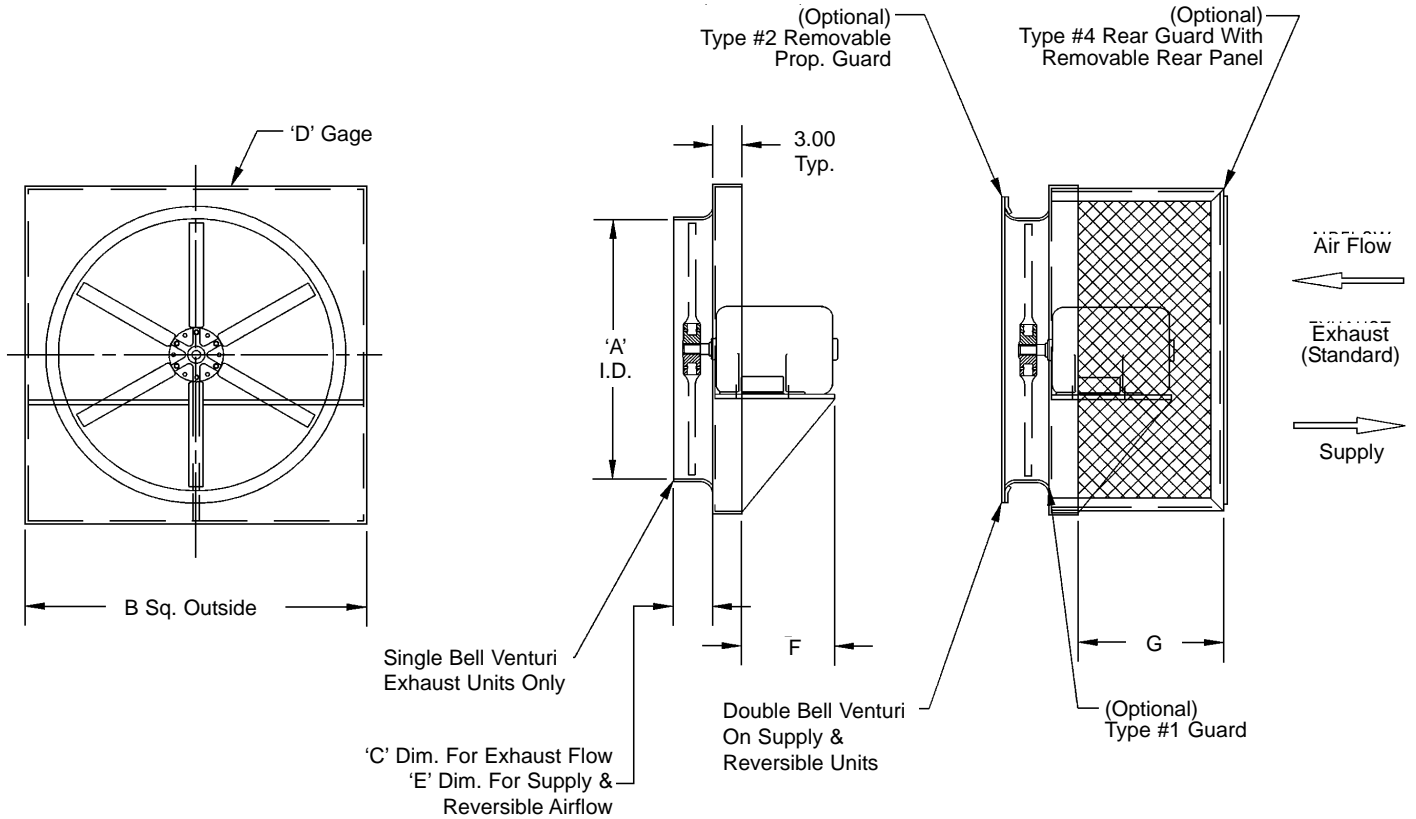

### Dimensional Data

| Size | A     | B     | C    | D  | E     | F Max | G     | Max. Motor | Unit Weight |
|------|-------|-------|------|----|-------|-------|-------|------------|-------------|
| 012  | 12.19 | 16.00 | 1.50 | 16 | 4.63  | 4.13  | 7.63  | 145T       | 15          |
| 015  | 15.19 | 19.00 | 2.00 | 16 | 5.13  | 4.13  | 7.63  | 145T       | 20          |
| 018  | 18.19 | 22.00 | 2.50 | 16 | 5.63  | 7.31  | 11.63 | 184T       | 30          |
| 021  | 21.22 | 25.00 | 2.50 | 16 | 5.63  | 7.31  | 11.63 | 184T       | 35          |
| 024  | 24.25 | 28.00 | 3.00 | 16 | 6.13  | 6.56  | 15.88 | 184T       | 40          |
| 027  | 27.28 | 34.00 | 3.00 | 16 | 6.13  | 6.25  | 15.88 | 184T       | 60          |
| 030  | 30.31 | 36.00 | 3.50 | 14 | 7.50  | 8.63  | 18.88 | 215T       | 80          |
| 032  | 32.34 | 38.00 | 3.50 | 14 | 7.50  | 8.63  | 18.88 | 215T       | 90          |
| 036  | 36.38 | 42.00 | 4.00 | 14 | 9.00  | 13.63 | 18.88 | 256T       | 110         |
| 042  | 42.44 | 48.00 | 4.75 | 14 | 9.75  | 12.75 | 18.88 | 256T       | 160         |
| 048  | 48.50 | 54.00 | 4.75 | 14 | 9.75  | 12.81 | 17.88 | 256T       | 200         |
| 054  | 54.56 | 60.00 | 5.00 | 14 | 11.75 | 12.19 | 17.88 | 256T       | 240         |
| 060  | 60.63 | 66.00 | 5.00 | 14 | 11.75 | 11.88 | 17.88 | 256T       | 270         |

- Notes:**
1. Approximate fan weights are less motor and accessories.
  2. Propeller is six-bladed cast aluminum.
  3. See Direct Drive, Design 2, Submittal ES-PND-DD2, for larger motor frame sizes.

|  |   |
|--|---|
|  <p><b>PENNBARRY™</b></p> <p>1401 North Plano Road, Richardson, TX 75081<br/>Ph: 972.234.3202 Fax: 972.497.0468<br/>www.PennBarry.com</p> | <h2 style="margin: 0;">Submittal Sheet</h2> <h3 style="margin: 0;">PND Panel Fan</h3> <h4 style="margin: 0;">Design 1</h4> <h4 style="margin: 0;">Direct Drive</h4> |
|--|---|

This drawing illustrates our understanding of order requirements. When approved, it represents details for fabrication, as such, PennBarry will not be responsible for revisions in the field or other changes after release for fabrication. Published and protected by PennBarry, Richardson, TX. All rights reserved. May not be reproduced partially or in full without permission from the publisher. No rights conveyed to manufacture partially or in full, use or sell either the method of construction represented or any invention in any way related thereto.