

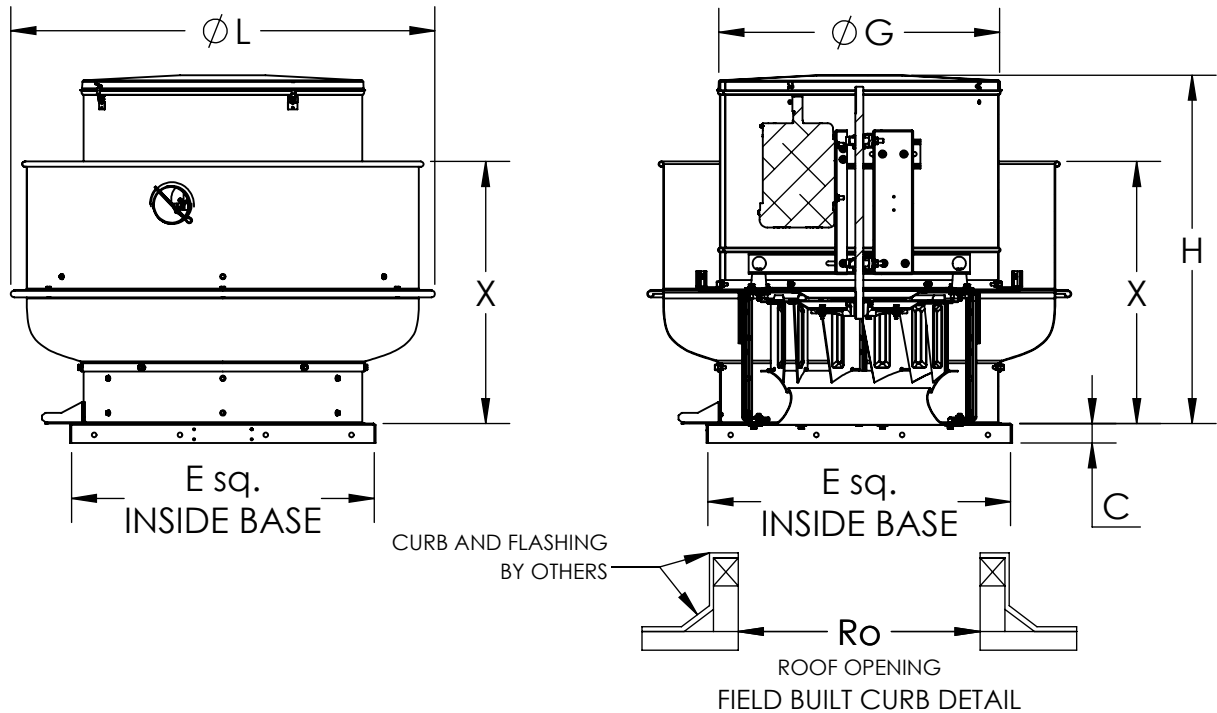

DATE: TAG:
 JOB:
 PROJECT:
 COMPANY:
 SALES PERSON:

PRU-BD (UPBLAST CENTRIFUGAL FAN)
 POWER ROOF VENTILATOR - BELT DRIVE



Standard Construction

- 1) Backward Inclined Alum Wheel
- 2) Alum housing with Curb Cap
- 3) Galvanized motor structure with lifting lug
- 4) Drain Spout

Options & Accessories

- | | |
|-----------------------------------|------------------------|
| 1) Floating hinge kit | 6) Extended lube lines |
| 2) Hinge sub-base | 7) Curb Adaptor |
| 3) Pedestal (Vented & Non-Vented) | 8) Coatings |
| 4) Bird screen/Outlet Guard | 9) Disconnect Switch |
| 5) Back Draft & Control Damper | |

DIMENSIONAL DATA

SIZES	PARTIAL WIDTH 'X'					L	H	G	E	C	Ro	MAX MTR FRAME	MAX RPM	MAX WT. (lbs)
	110%	100%	80%	50%	30%									
060	-	14 15/16	-	-	-	25 1/4	21 1/2	16 1/4	17 1/8	1 13/16	9 1/2	48	4400	56
070	-	14 15/16	-	-	-	25 1/4	21 1/2	16 1/4	17 1/8	1 13/16	9 1/2	48	4400	57
080	-	14 15/16	-	-	-	25 1/4	21 1/2	16 1/4	17 1/8	1 13/16	9 1/2	48	4400	58
100	-	14 15/16	-	-	-	25 1/4	21 1/2	16 1/4	17 1/8	1 13/16	9 1/2	48	4400	55
122	-	18 1/8	-	-	-	30 1/4	24 1/2	19 3/4	21	1 13/16	13 1/2	48	3550	70
135	-	19 1/4	18 5/16	-	-	30 1/4	25 5/16	19 3/4	21	1 13/16	13 1/2	48	3222	75
150	-	20 3/4	19 11/16	-	-	33 1/4	26 1/4	21 7/8	23 3/8	1 13/16	16	145T	2900	80
165	22 5/16	21 3/4	20 9/16	18 7/8	-	36 1/4	29	24 1/8	25 5/8	1 13/16	18	145T	2636	90
182	24 11/16	24 1/16	22 3/4	20 7/8	-	39 3/4	32 9/16	26 5/8	28 3/8	1 13/16	21	184T	2300	105
200	25 3/4	25 1/16	23 11/16	21 9/16	-	43 1/4	33 13/16	29 1/8	31 1/8	1 13/16	23 1/2	184T	2100	110
222	28 3/4	27 15/16	26 3/8	24 1/16	-	47 3/4	35 7/8	32 1/4	34 9/16	1 13/16	27 1/2	184T	1888	130
245	30 13/16	29 15/16	28 3/16	25 5/8	23 7/8	47 3/4	37 5/16	32 1/4	34 9/16	1 13/16	27 1/2	215T	1714	143
270	34 3/16	33 1/4	31 5/16	28 1/2	26 9/16	52 3/8	39 3/4	35 1/2	38 1/4	1 13/16	31	215T	1556	162
300	35 5/16	34 1/4	32 1/8	28 15/16	26 7/8	57 3/4	41 3/4	39 3/8	42 1/2	1 13/16	35	215T	1400	190
330	39 1/16	37 7/8	35 9/16	32 1/16	29 3/4	63 1/4	43 7/8	43 3/8	46 5/8	1 7/8	39	215T	1273	250
365	41 7/16	40 1/8	37 9/16	33 11/16	31 1/8	69 5/8	46 1/2	47 7/8	51 5/8	1 7/8	44	215T	1151	280
402	-	41 11/16	38 7/8	34 9/16	31 3/4	76 7/16	48 15/16	52 3/4	56 7/8	1 7/8	49 1/2	215T	1044	325
445	-	45 3/8	42 1/4	37 9/16	34 3/8	71 1/4	51 9/16	51 1/8	55 1/4	1 7/8	48	215T	944	390
490	-	49	45 9/16	40 3/8	36 15/16	78 1/8	57 1/4	56 1/4	60 3/4	1 7/8	53 1/2	254T	857	460
542	-	53 7/16	49 5/8	43 7/8	40 1/16	86 1/4	60 3/4	62 1/4	67 3/8	1 7/8	60	254T	774	532

ALL DIMENSIONS ARE IN INCHES, WEIGHTS ARE APPROXIMATE AND DOES NOT INCLUDE DRIVES OR ACCESSORIES.

REVISION:	FORM:	REPLACES:
-----------	-------	-----------