

DYNAMO

General Purpose Centrifugal Fan

OPERATION & MAINTENANCE MANUAL



PENNBARRY™

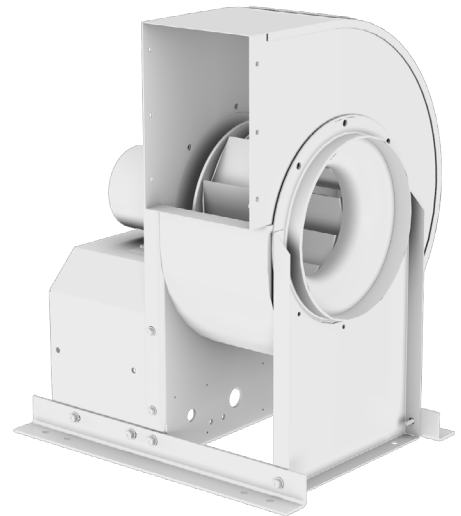
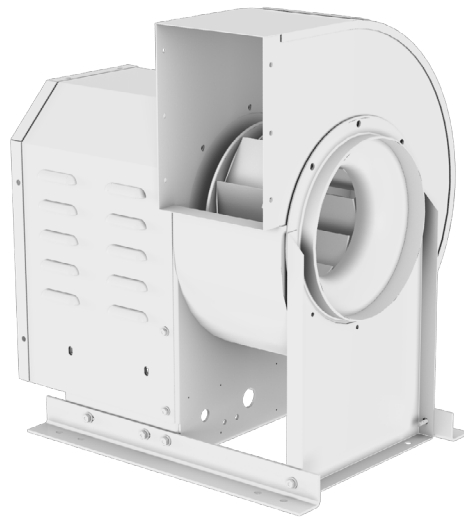

IMPORTANT! Read before proceeding!

The information contained herein is, to the best of our knowledge, accurate and applicable for proper operation and installation of the specified equipment at the time this document entered service. Before proceeding, it is recommended that you check for a more current version of this Installation Operation Manual (IOM) on our website at www.pennbarry.com.

Read carefully before attempting to assemble, install, operate or maintain the product described. Protect yourself and others by observing all safety information. Failure to comply with instructions could result in personal injury and/or property damage! Retain instructions for future reference.

TABLE OF CONTENTS

INTRODUCTION	3
INSTALLATION	4
START-UP AND OPERATION	5-6
MAINTENANCE	7
REPLACEMENT PARTS	8
ACCESSORIES AND DUCT ARRANGEMENTS	9
UNIPAK TYPICAL INSTALLATION	10-11
WIRING HARNESS – ECM	12-14
TROUBLESHOOTING CHECKLIST	15

INTRODUCTION

Receiving and handling

PennBarry fans are carefully inspected before leaving the factory. When the unit is received, inspect the carton for any signs of tampering. Inspect the unit for any damage that may have occurred during transit and check for loose, missing or damaged parts. Mishandled units can void the warranty provisions. If units are damaged in transit, it is the responsibility of the receiver to make all claims against the carrier. PennBarry is not responsible for damages incurred during shipment.

Avoid severe jarring and/or dropping. Handle units with care to prevent damage to components or finishes. If the unit is scratched due to mishandling, the protective coating may be damaged. Incorrect lifting may damage the fan and void the warranty.

Storage

Long-term storage requires special attention. Store units on a level, solid surface, preferably indoors. If outside storage is necessary, protect the units against moisture and dirt by encasing the cartons in plastic or in some similar weatherproof material. Periodically inspect units and rotate wheels to spread bearing lubricant. Failure to rotate wheels results in reduced bearing life and may void the manufacturer's warranty. If the unit is a belt driven model and will be stored for an extended time, remove belts; belts which remain under tension in a stationary position for extended periods are likely to have a reduced operating life.

Unpacking

Place the carton in an upright position and remove the staples or use a sharp (knife edge) tool to carefully cut or scribe the sealing tape on both sides at the top of the carton. Open carton flaps. Remove any cardboard and wooden filler pieces, as well as loose components or accessories shipped with the unit.

Carefully remove the unit from the carton. Inspect the unit for any damage that may have occurred during transit and check for loose, missing or damaged parts.

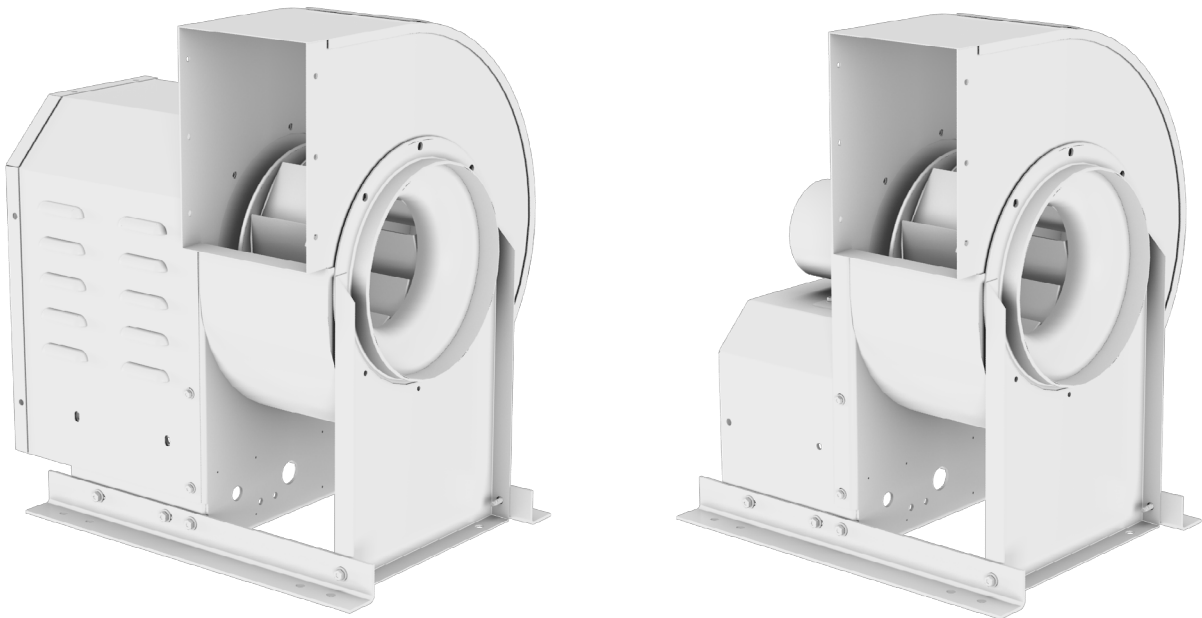

INSTALLATION

For all units, determine the minimum safe floor or roof loading requirement for proper support, by multiplying the total weight of the unit by two. Follow local codes and good practices to ensure proper anchoring of roof top units. A minimum of 12" clearance should be provided for adequate heat dissipation. For these units, flex pads and other isolators are available to reduce the transmission of vibration to the surrounding areas. See suggested ductwork installations and the dimensional information on page 9 and 11. Blowers suitable for Restaurant Exhaust Appliances (YZHW) are accordingly labeled. These units require installation according to NFPA96 Standards, local codes and general practices. For curb mounting, to ensure a positive seal, apply a high temperature gasket material on the roof curb.

Installing Dampers

When required, install dampers prior to mounting the unit on the curb or frame. Secure dampers to the inside of the curb without undue twisting, which may distort the damper frame. Damper frame must be reasonably level on all sides. Check for free operation. If dampers are motor operated type, ascertain that proper voltage is impressed on motor terminals.

Positioning and Running Power Lines

Power is normally brought from within the building and placed inside one corner of the curb. Feed power line through the clearance hole provided in the damper and in turn through the electrical conduit hole provided in the base of the exhauster (fed through rubber grommets on smaller units). If local codes require special electrical wire of unusually large size, then remove and discard the electrical conduit (or grommets).

Installing the Fan

For access to motor and drive assembly, simply remove or lift access hood and make necessary power connections to motor (through service switch if required). Provide a generous amount of slack in power line between motor and service switch to allow for motor deflections and to permit movement or motor for belt tension adjustments.

Anchoring or Securing the Unit

Whenever possible, anchor the fan by fastening through the vertical portion of the mounting flange. The type of fastener depends upon curb construction, and using two fasteners per side constitutes adequate anchoring under normal conditions. If code or specification prescribes fastening through the top (horizontal portion) of the mounting flange, use neoprene or lead washers under the head of each fastener to prevent water leaks.



Guy down large units installed in areas subject to high winds or unusual field conditions.

To complete the re-assembly of the unit, secure hood to frame by replacing all spacers, washers and nuts exactly as they were found prior to removal. The unit is now ready for service.

Apply power and check rotation as indicated by arrow in motor compartment. The rotation of all centrifugal ventilators is counterclockwise when viewing the unit from above the motor compartment.

START-UP AND OPERATION

Carefully inspect the unit before start-up. All motor bearings should be properly lubricated (belt driven units only), and all fasteners should be securely tightened. Rotate blower wheels by hand to ensure free movement. Make sure the inlets and approaches to the exhauster are clean and free from obstruction. To ensure maximum air movement, adequate supply air must be available.

Rough shipping or handling may cause the wheel or propeller to move away from the venturi inlet. That condition can cause the fan to move less air. If that occurs, loosen set screws and adjust the impeller closer to the inlet. Retighten all hardware securely.

Belt Tension Check-Up (Belt Driven Units Only)

Check condition of belts and the amount of tension prior to start-up. When it becomes necessary to adjust belt tension, do not overtighten as bearing damage will occur. Recommended belt tension should permit deflection of $1/64$ " per inch of span of the belt on each side of the belt measured halfway between the pulley centerline. Exercise extreme care when adjusting belts as not to misalign the pulleys. Any misalignment will cause a sharp reduction in belt life and produce squeaky, annoying noises (See figure 1). On units equipped with two or three groove pulleys, adjust all belts with equal tension.

Figure 1: Pulley Alignment

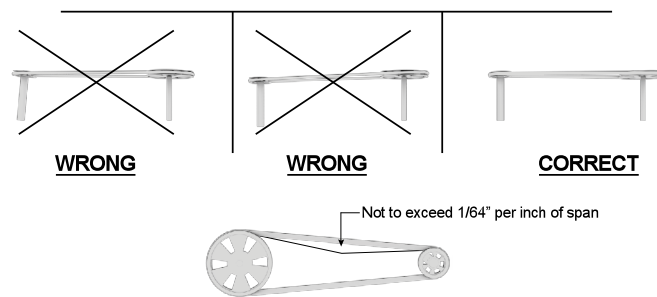

Whenever belts are removed or installed, never force belts over pulleys without loosening motor first to relieve belt tension.

Before applying power to the motor, check the following:

1. Turn off and LOCK OUT the power source.
2. Check line voltage with motor nameplate.
3. On single phase motors, set-up the terminal blocks in accordance with the nameplate instructions (or wiring diagram). The set up must match the line voltage.
4. If the motor is three phase, group and connect the winding leads as shown on the wiring diagram. The line voltage must correspond with proper grouping of motor leads.
5. On two speed motors, follow the wiring diagram explicitly, or serious motor damage will occur.
6. For ECM direct driven motors, make sure that the integrated potentiometer is adjusted to its minimum set point by rotating it counter clockwise until you reach its stop before starting fan.
7. Activate the blower and allow it to operate.
8. For ECM direct driven motors, slowly start adjusting the pot to the desired motor RPM.
9. Carefully check the rotation of the wheel to ensure operation in the proper direction.

START-UP AND OPERATION



CAUTION

Incorrect rotation overloads motor severely and results in serious motor damage. To change rotation of three phase units, simply interchange any two of the three line leads. On single phase units, change the terminal block set-up following the wiring diagram.

10. Check that bearing temperatures are not excessively hot.
11. Check that all bolts and hangers are secure after one (1) hour of continuous operation.

NOTE: Take care to follow all local electrical, safety and building codes. Follow provisions of the National Electrical Code as well as the Occupational Safety and Health Act.



CAUTION

Always disconnect power source before working on the unit.

Guard and Protect All Moving Parts

All motors are checked prior to shipment. However, if motor defects should develop, prompt service can be obtained from the nearest authorized service station of the motor manufacturer under the warranty. Exchange, repair or replacement will be provided on a no charge basis if the motor is defective within the warranty period. Do not return defective motors to PennBarry. Motor guarantee is void unless overload protection is provided in motor wiring circuit.

MAINTENANCE

Do not attempt maintenance on fan until the electrical supply has been completely disconnected. If a service switch has not been provided, remove all fuses from the circuit and lock the fuse panel so they cannot be accidentally replaced.

Lubrication is a primary maintenance responsibility. Check all bearings periodically. Inspect belts for tightness. If the fan is installed in a corrosive or dirty atmosphere, periodically clean the centrifugal wheel, inlet, motor housing and other moving parts.

Fan Shaft Lubrication (Belt Drive models only)

Fan shaft bearing pillow blocks are furnished in either the prelubricated sealed-for-life type or the greasable type depending on what was ordered. The prelubricated type requires no servicing for 7 to 10 years of normal use, and the greasable type are factory greased eliminating the need for greasing initially. Follow the lubricating schedule recommended by the factory. This practice should not supersede any safety considerations.



Use low pressure grease guns only. High pressure guns tend to blow out or unseat bearing seals, leaving the bearing open to collect grime, dust and foreign particles.

Lubrication Schedule

Always follow the bearing manufacturer's recommended lubrication schedule. If none is available, use the following general schedule:

1. Under average conditions where ambient temperatures do not exceed 120°F, lubrication is required 1 to 2 times a year.
2. In dirt laden atmospheres where there is a temperature range of 120°F to 150°F, lubrication is required from 3 to 6 times a year.
3. Under extreme temperature conditions and extremely dirty atmospheres, lubrication should be scheduled at least once or twice a month.
4. Belt drive units maximum temperature should not exceed 160°F. Direct driven models have temperature range stamped on motor.

Motor Lubrication

In general, standard motors are furnished with prelubricated, sealed-for-life ball bearings which require no lubrication for 7 to 10 years of normal service. Where motors have been ordered with greasable bearings, these bearings are factory lubricated and require no attention for one year under normal conditions. If grease relief fittings are provided, remove them when performing maintenance to allow grease to flow out. Whenever possible, apply grease while the motor is running. This practice should not supersede any safety considerations. DO NOT OVERGREASE, as most lubricants deteriorate motor windings, thereby reducing motor life.

Recommended Lubricants

Manufacturer	Product	Temp. Range
BP	LG-#P-1	Below 32°F (0°C)
Gulf	Gulfcrown EP-1	
Imperial Oil	Unirex EP-1	
Shell	Alvania R-1	
BP	Energrease, MPMK11	32°F to 150°F (0°C to 66°C)
Gulf	Gulfcrown EP-2	
Imperial Oil	Unirex EP-2	
Shell	Alvania R-3	
Sun Oil	Sun Prestige 42	
Texaco	Regal AFB2	

REPLACEMENT PARTS

Replace parts with components which duplicate original parts correctly. Incorrectly sized shafts, belts, pulleys, etc. can damage the fan.

Spare or replacement parts and prices are available upon request. Please supply the following information: Factory Order Number, Customer's Name and Order Number, and Date. If this information is not available, furnish a complete description of the part required. Names of parts are shown on the following drawing. To order motors, provide the HP, RPM, voltage, phase, hertz and type of enclosure.

CENTRIFUGAL BLOWER CLASS 1, S.W.S.I.

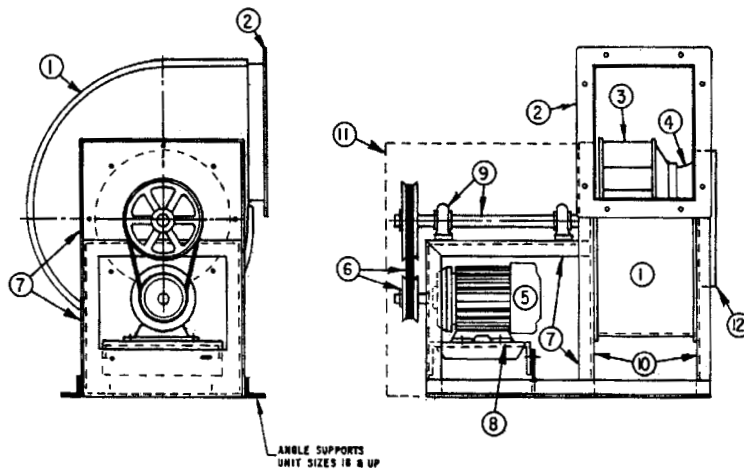

Part	Description
1	Blower Scroll Housing
2	Outlet Duct Flange (optional)
3	Centrifugal Wheel (aluminum non- overloading)
4	Spun Inlet
5	Ball Bearing Motor
6	Belt and Pulleys
7	Drive Frame Support Assembly
8	Adjustable Motor Mouthing Plate
9	Fan Shaft and Bearings
10	Support Legs with Mounting Holes
11	Belt and Bearing Enclosure (Optional)
12	Round Inlet Ring

DIRECT DRIVE CENTRIFUGAL BLOWER CLASS 1, S.W.S.I

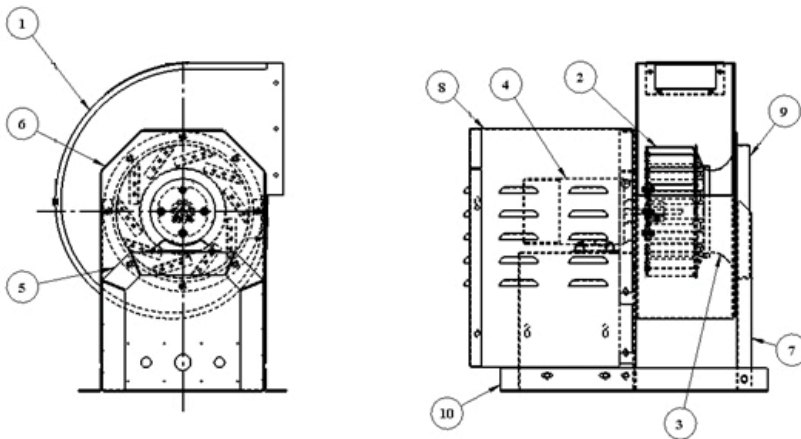

Part	Description
1	Blower Scroll Housing
2	Centrifugal Wheel (aluminum non- overloading)
3	Spun Inlet
4	EC Motor
5	Motor Mount
6	Drive Frame Support
7	Support Legs with Mounting Holes
8	Weather Cover
9	Round Inlet Ring
10	Angle Supports

ACCESSORIES AND DUCT ARRANGEMENTS

BLOWER ACCESSORIES

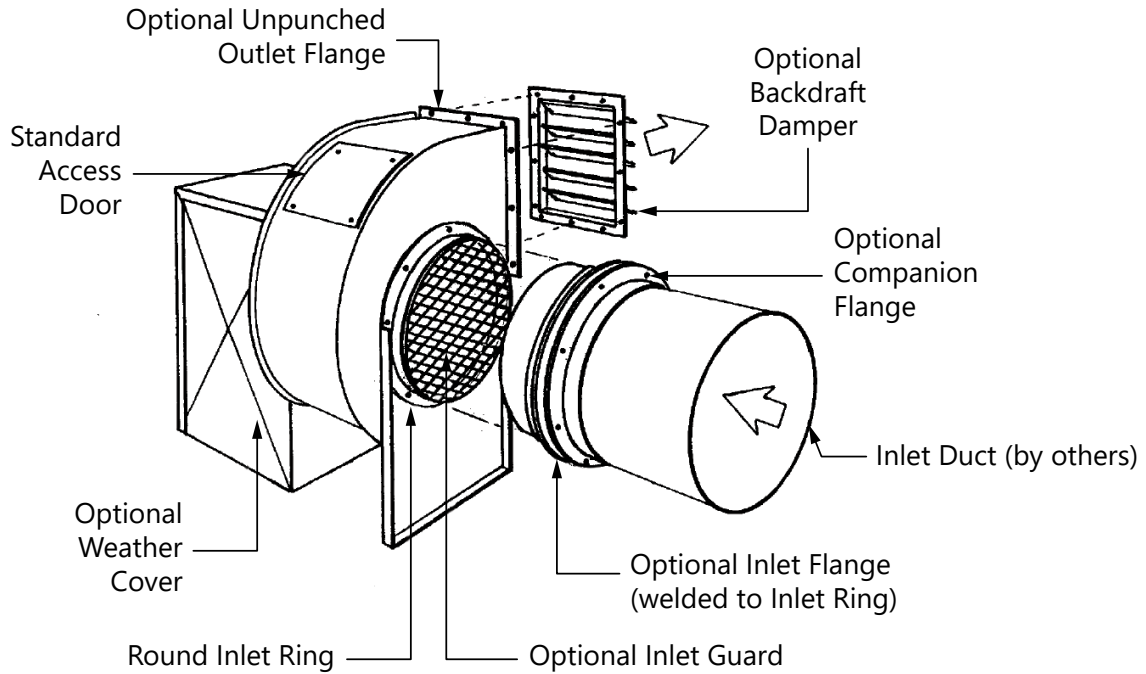

CORRECT INLET & OUTLET DUCT ARRANGEMENTS

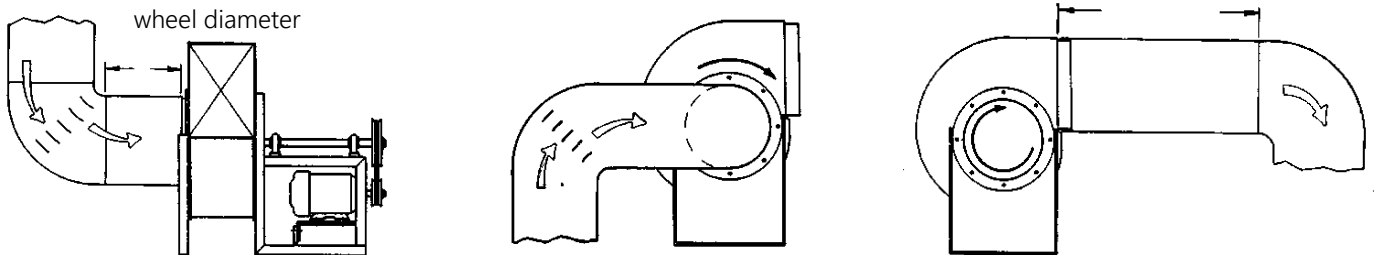

INCORRECT INLET & OUTLET DUCT ARRANGEMENTS

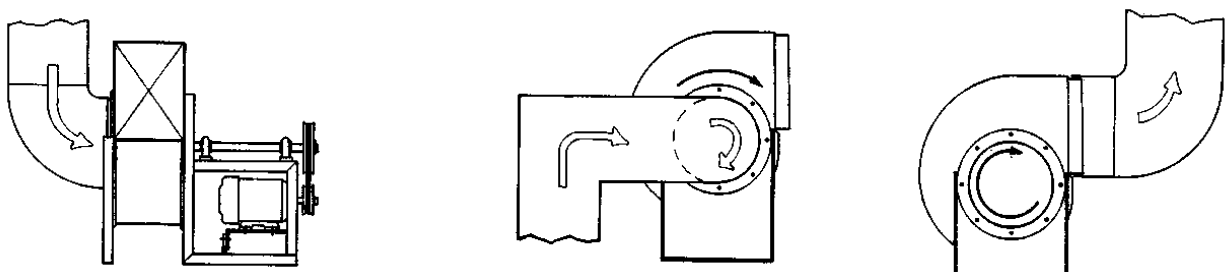

DYNAPAK TYPICAL INSTALLATION

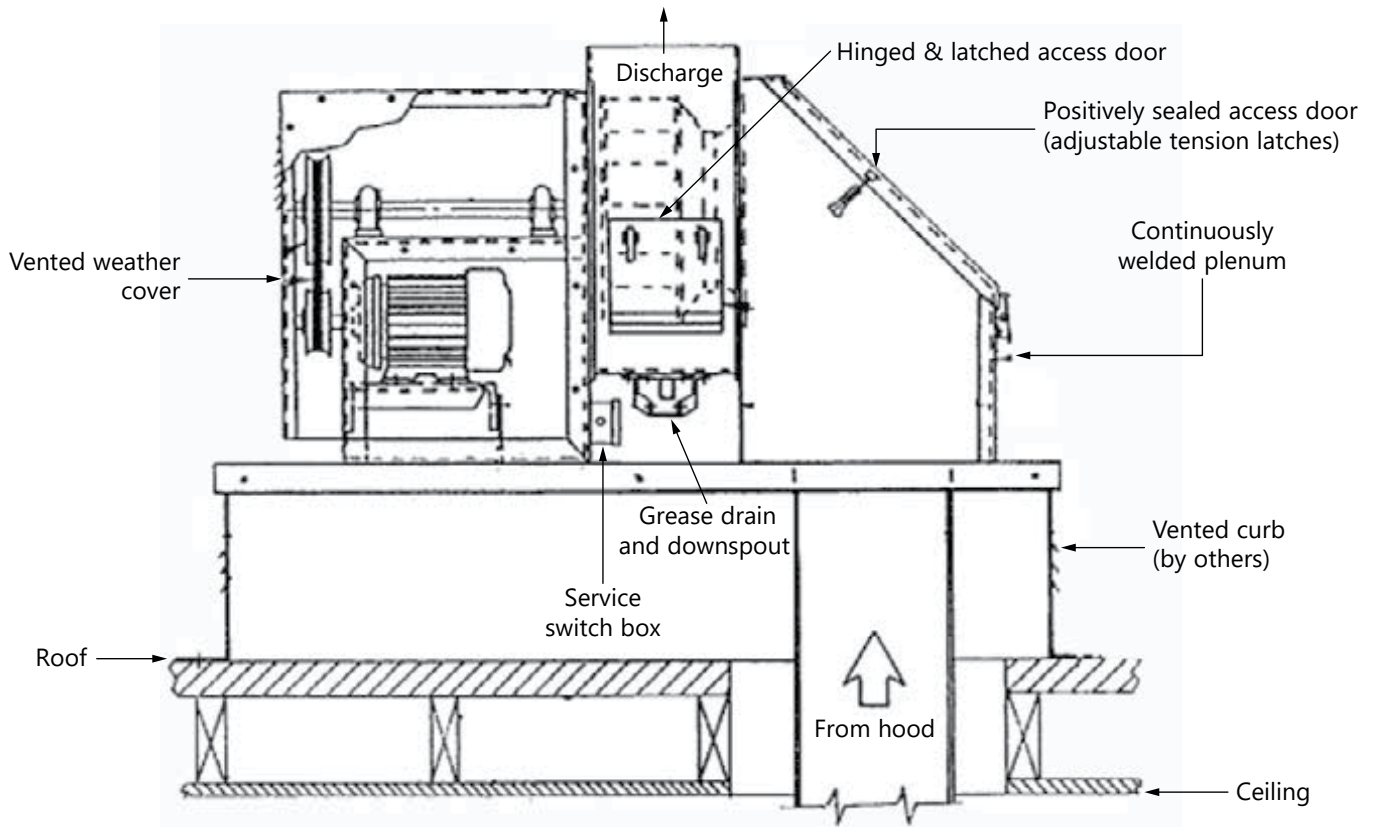

DYNAPAK TYPICAL INSTALLATION

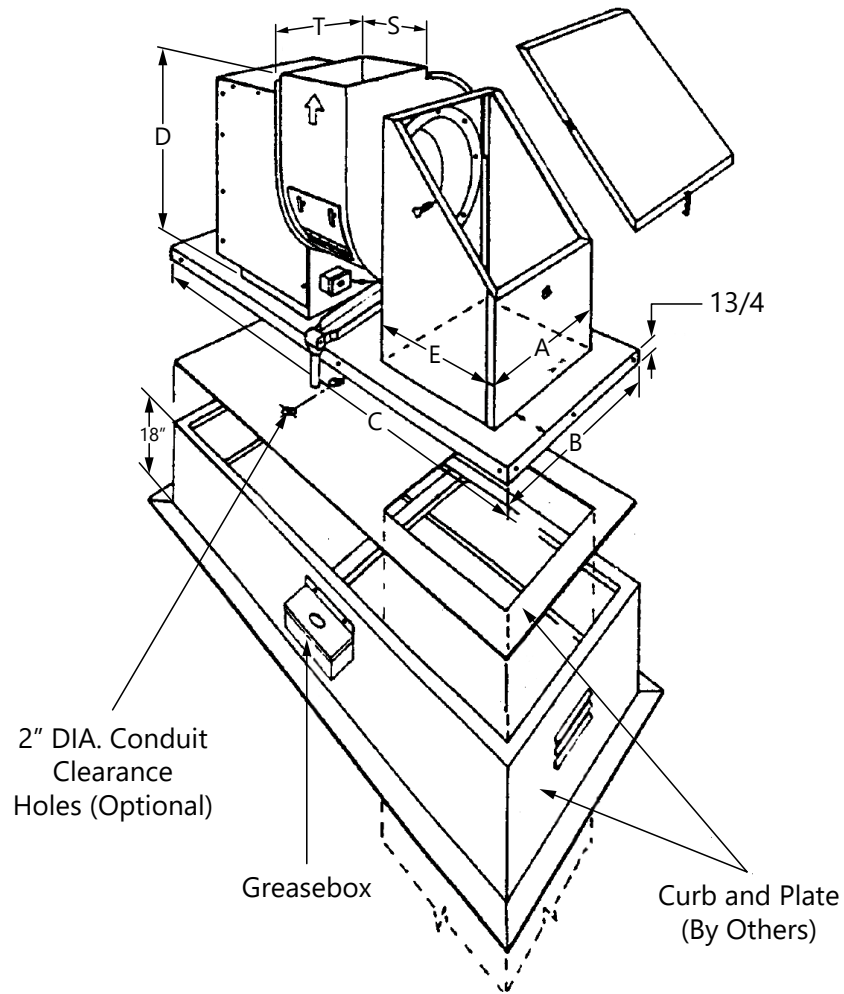

Model	A	B	C	D	E	F	G
US10DP	3/4"	14 1/4"	26 1/8"	52 1/8"	24 1/8"	17 9/16"	5 1/32"
US13DP	1"	17 7/16"	28 1/8"	56 1/8"	28 5/16"	17 5/16"	4 31/32"
US16DP	1 3/16"	20 15/16"	34 1/8"	68 1/8"	34 5/16"	20 13/16"	6 1/32"
US20DP	1 3/16"	24 1/2"	40 3/16"	80 3/16"	40 5/16"	24 5/16"	6 1/32"
US24DP	1 7/16"	29 5/16"	44 3/16"	88 3/16"	48 3/4"	29 1/16"	5 31/32"

Model	S	T
US10DP	8 1/4"	11 1/4"
US13DP	10 1/2"	14 3/8"
US16DP	12 3/4"	17 1/2"
US20DP	14 3/4"	21 3/4"
US24DP	19"	26"

WIRING HARNESS – ECM

1) T.E. Motors 120v/240v/460v Single Phase (control provided by others)

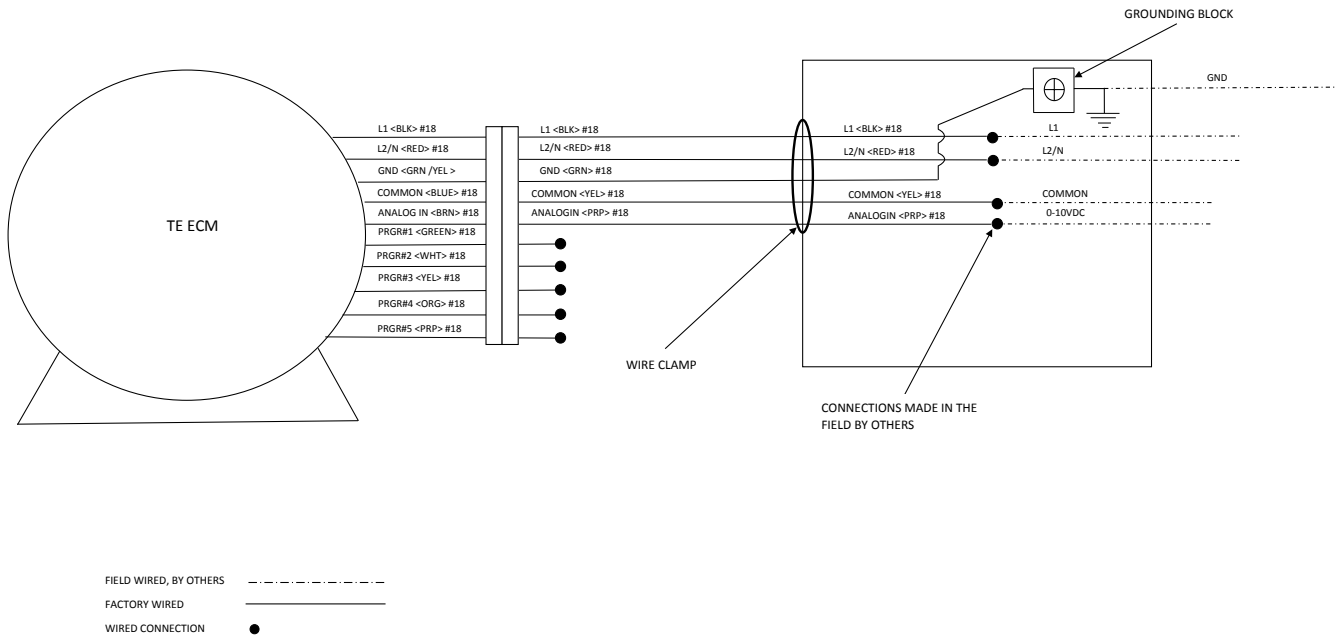

2) T.E. Motors 120v/240v Single Phase (0-10V output potentiometer)

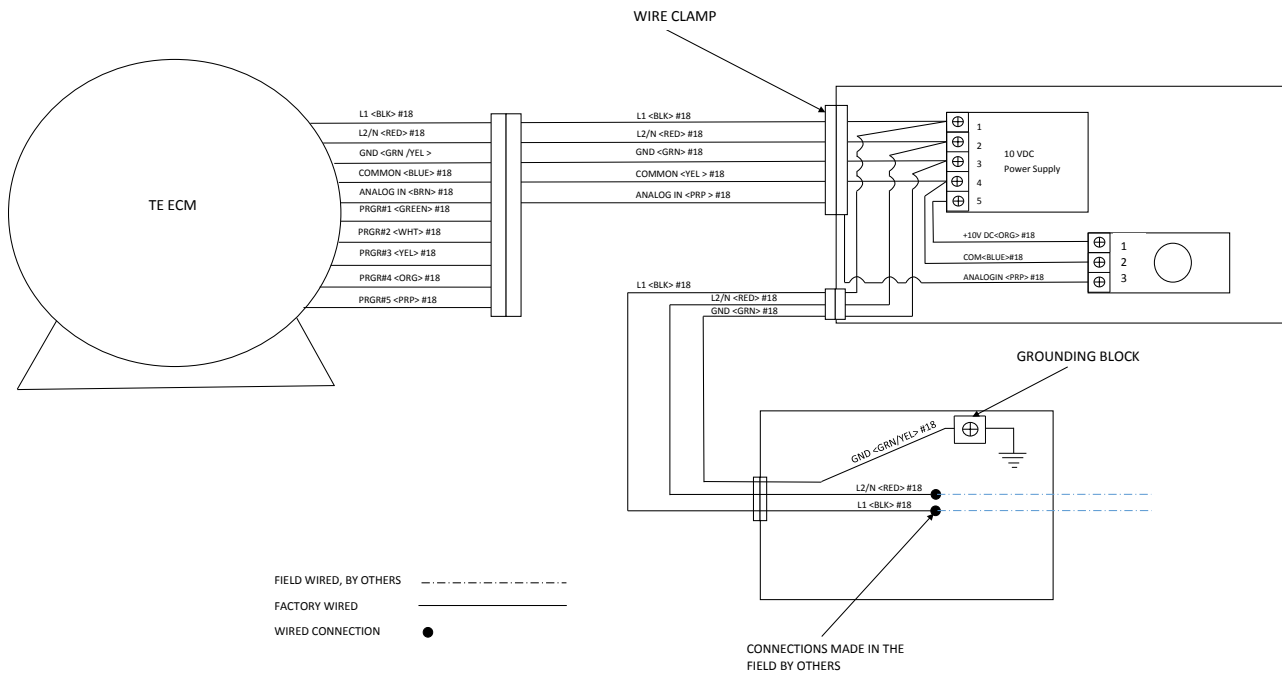

This drawing illustrates our understanding of order requirements. When approved, it represents details for fabrication, as such, PennBarry will not be responsible for revisions in the field or other changes after release for fabrication. Published and protected by PennBarry, Plano, TX. All rights reserved. May not be reproduced partially or in full without permission from the publisher. No rights conveyed to manufacture partially or in full, use or sell either the method of construction represented or any invention in any way related thereto.

WIRING HARNESS – ECM

3) T.E. Motors 120v/240v/460v Single Phase (with iQ-IPCM controller)

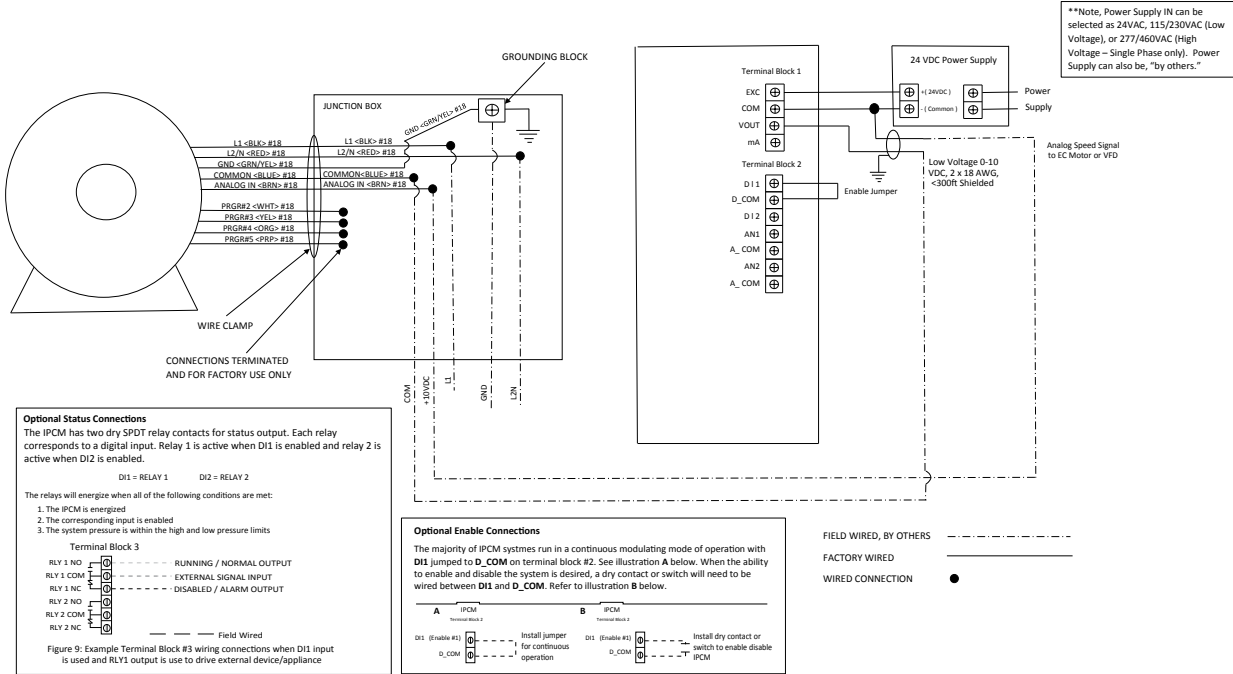

4) T.E. Motors 120v/240v/460v Single Phase (with iQ-MS controller)

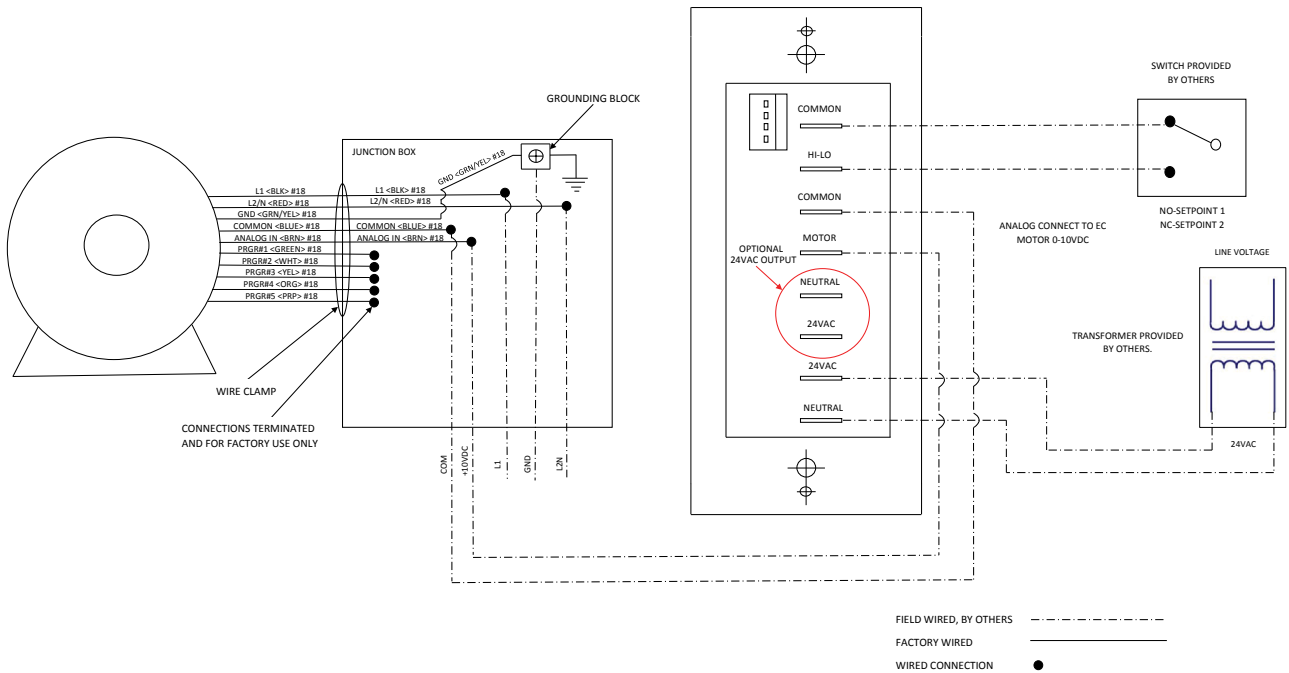

This drawing illustrates our understanding of order requirements. When approved, it represents details for fabrication, as such, PennBarry will not be responsible for revisions in the field or other changes after release for fabrication. Published and protected by PennBarry, Plano, TX. All rights reserved. May not be reproduced partially or in full without permission from the publisher. No rights conveyed to manufacture partially or in full, use or sell either the method of construction represented or any invention in any way related thereto.

WIRING HARNESS – ECM

5) T.E. Motors 208v/460v Three Phase

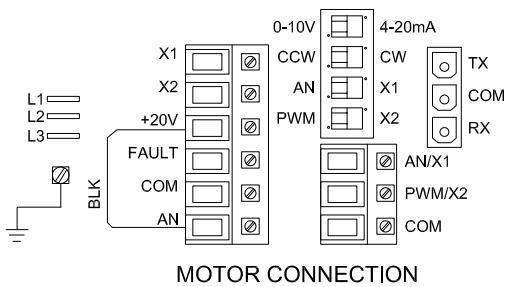
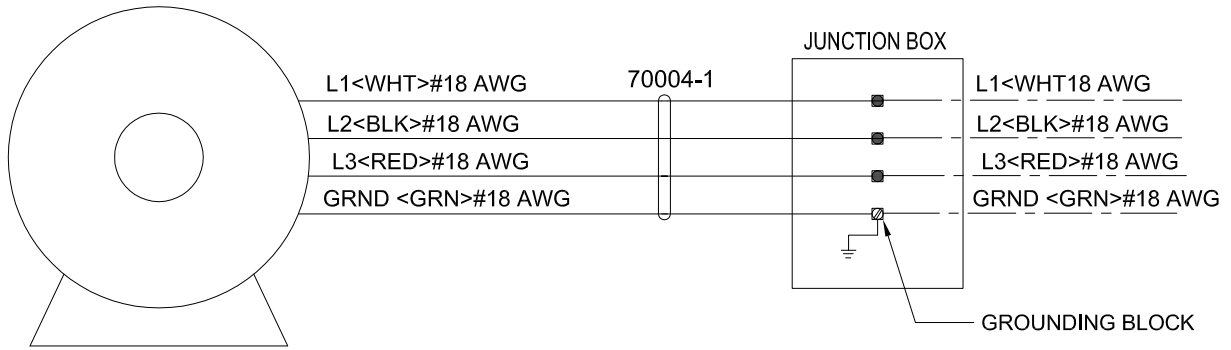

This drawing illustrates our understanding of order requirements. When approved, it represents details for fabrication, as such, PennBarry will not be responsible for revisions in the field or other changes after release for fabrication. Published and protected by PennBarry, Plano, TX. All rights reserved. May not be reproduced partially or in full without permission from the publisher. No rights conveyed to manufacture partially or in full, use or sell either the method of construction represented or any invention in any way related thereto.

TROUBLESHOOTING CHECKLIST

Symptom	Possible Cause(s)	Corrective Action
Excessive Noise	1. Defective or loose motor bearings.	1. Replace motor with same frame size, RPM, HP.
	2. Ventilator base not securely anchored.	2. Reset properly.
	3. Loose or unbalanced wheel/propeller.	3. Tighten screws, remove build-up, balance wheel/propeller.
	4. Misaligned pulleys or shaft.	4. Correct alignment.
	5. Loose or damaged wheel/propeller.	5. Replace wheel/propeller.
	6. Wheel running in wrong direction.	6. Reverse direction.
Fan Inoperative	1. Blown fuse or open circuit breaker.	1. Replace fuses or circuit breaker.
	2. Loose or disconnected wiring.	2. Shut off power and check wiring for proper connections.
	3. Defective motor.	3. Repair or replace motor.
	4. Broken belts.	4. Replace belts.
	5. No 0-10v signal going into the motor (direct driven model only)	5. Make sure the included Pot is not in the off position.
Insufficient Airflow	1. Open access doors or loose sections of ducts.	1. Check for leakage.
	2. Clogged filters.	2. Clean filters.
	3. Operation in wrong direction.	3. Correct rotation of wheel.
	4. Insufficient make-up air direction.	4. Add make-up fan or louver opening.
	5. Damper (if installed) in the wrong position.	5. Adjust damper opening.
Water Leaking into Ductwork or Collection of Grease Under Fan	1. Fan installed with slope in the wrong direction.	1. Slope should be fitted in the direction of the drainage opening or grease collection box and drain spout.
	2. Clogged drain spout.	2. Clean drain spout.
	3. Grease container full.	3. Empty grease box.
Motor Overheating	1. Belt slippage (belt drive units only).	1. Adjust tension or replace belts.
	2. Overvoltage or under voltage.	2. Contact power supply company.
	3. Operation in wrong direction.	3. Reverse direction of motor.
	4. Fan speed too high.	4. Slow down fan by opening variable pitch pulley on motor shaft.
	5. Incorrect motor. (service factor 1.0, low ambient temp.)	5. Replace motor with correct open, NEMA service factors (1.15 or higher) with 40 degrees ambient.
	6. Insufficient airflow to kitchen hood fan operating on low speed with kitchen in full operation.	6. Check airflow under hood and adjust kitchen equipment output.
	7. Undersized motor.	7. Check motor ratings with catalog speed and air capacity chart.

Note: Care should be taken to follow all local electrical, safety and building codes. Provisions of the National Electric Code (NEC), as well as the Occupational Safety and Health Act (OSHA) should be followed.

All motors are checked prior to shipment. If motor defects should develop, prompt service can be obtained from the nearest authorized service station of the motor manufacturer while under warranty. Exchange, repair or replacement will be provided on a no charge basis if the motor is defective within the warranty period. Contact PennBarry for an authorized service station if requested.

WARNING: Motor guarantee is void unless overload protection is provided in motor wiring circuit.



PENNBARRY™

PennBarry is proud to be your preferred manufacturer of commercial and industrial fans and blowers. Learn how PennBarry can assist you in your next application by contacting your PennBarry Representative or visiting us on the web at www.pennbarry.com.

PennBarry | www.pennbarry.com | pbtsr@pennbarry.com | tel: 765.483.5800

PennBarry reserves the right to make changes at any time, without notice, to models, construction, specifications, options and availability. This manual illustrates the appearance of PennBarry products at the time of publication.

View the latest updates on the PennBarry website.

© 2018 PennBarry. All Rights Reserved. Revised FEBRUARY 2025